

PLAN
SCALE: $\frac{1}{4}$ " = 1'-0"

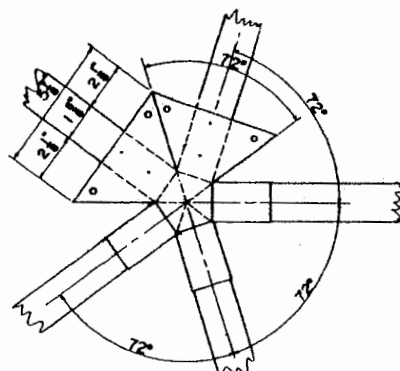

PLAN OF AERIAL JOINT
SCALE: $\frac{3}{8}$ " = 1'-0"

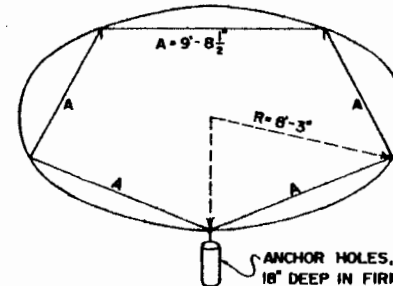

NOTE: FOUNDATION POINTS WILL ALL BE SAME DISTANCE "A" AND ON THE SAME RADIUS "R" FROM THE CENTER POINT.

PUT STAKE AT EACH MEASURED POINT TO MARK HOLE LOCATION

ANCHOR HOLES, 8" DIA.
18" DEEP IN FIRM SOIL
24" DEEP IN LOOSE SOIL

FOUNDATION LAYOUT
SCALE: $\frac{1}{4}$ " = 1'-0"

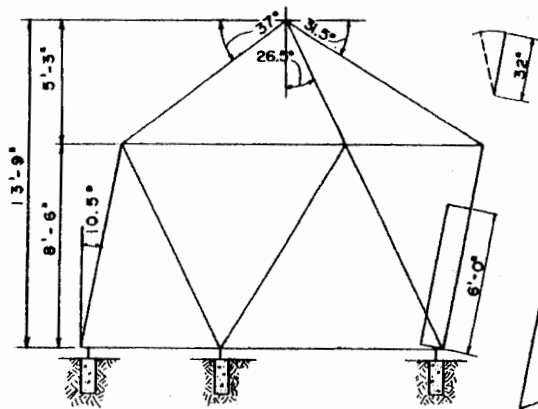

ELEVATION
SCALE: $\frac{1}{4}$ " = 1'-0"

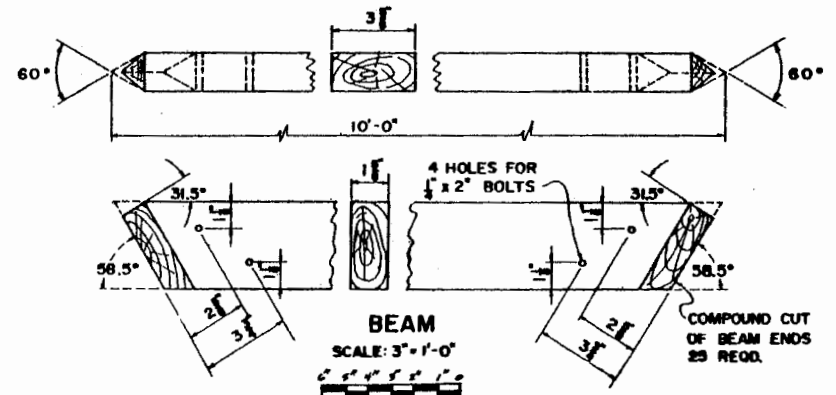
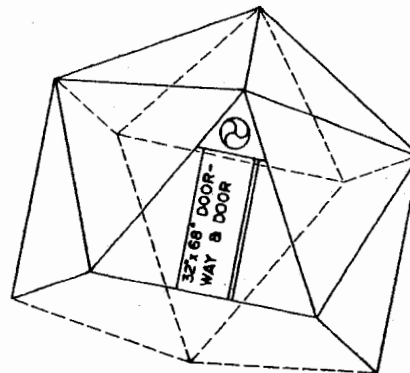

BEAM
SCALE: $\frac{3}{8}$ " = 1'-0"

COMPOUND CUT OF BEAM ENDS 23 REQD.

BEND GALVANIZED STEEL PLATE 26.5° UP ON ONE LEG OF OUTER PLATE AND 26.5° DOWN ONE LEG OF INNER PLATE. FOR CONNECTION TO ANCHOR STAKE BEND 31.5° DOWN FOR OUTER PLATE AND UP FOR INNER PLATE ON ALL FIVE LEGS.

18 GAGE GALV. STEEL JOINT PLATES BOTH ABOVE & BELOW EACH END OF 2x4 BEAMS

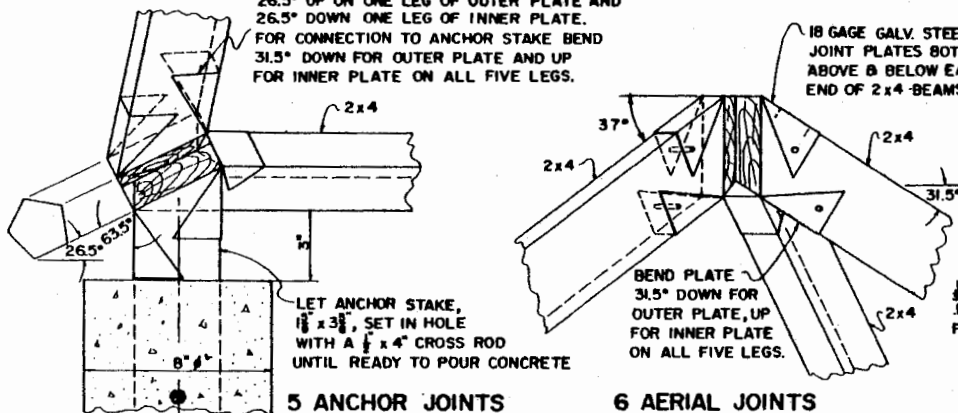

5 ANCHOR JOINTS
SCALE: $\frac{3}{8}$ " = 1'-0"

6 AERIAL JOINTS
SCALE: $\frac{3}{8}$ " = 1'-0"

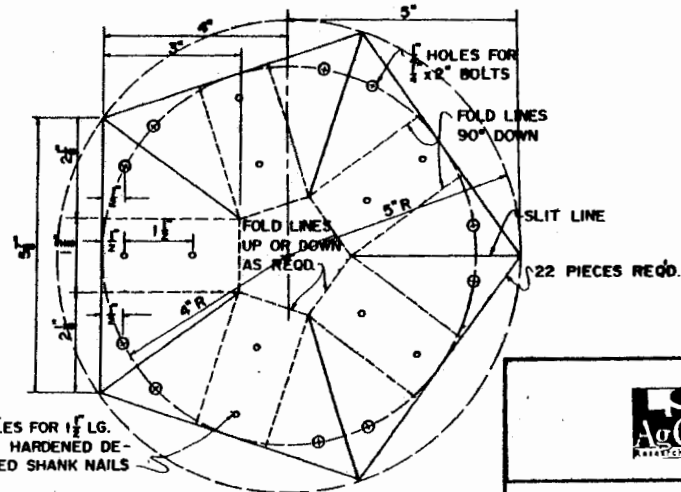

HOLES FOR 1 1/2 LG. 135° # HARDENED DEFORMED SHANK NAILS

JOINT PLATE OF 18 GAGE STEEL
SCALE: HALF SIZE



TRI-PENTA GREENHOUSE

USDA 71 6097 SHEET 1 OF 3

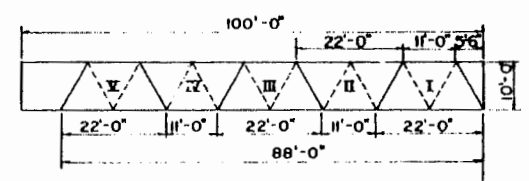
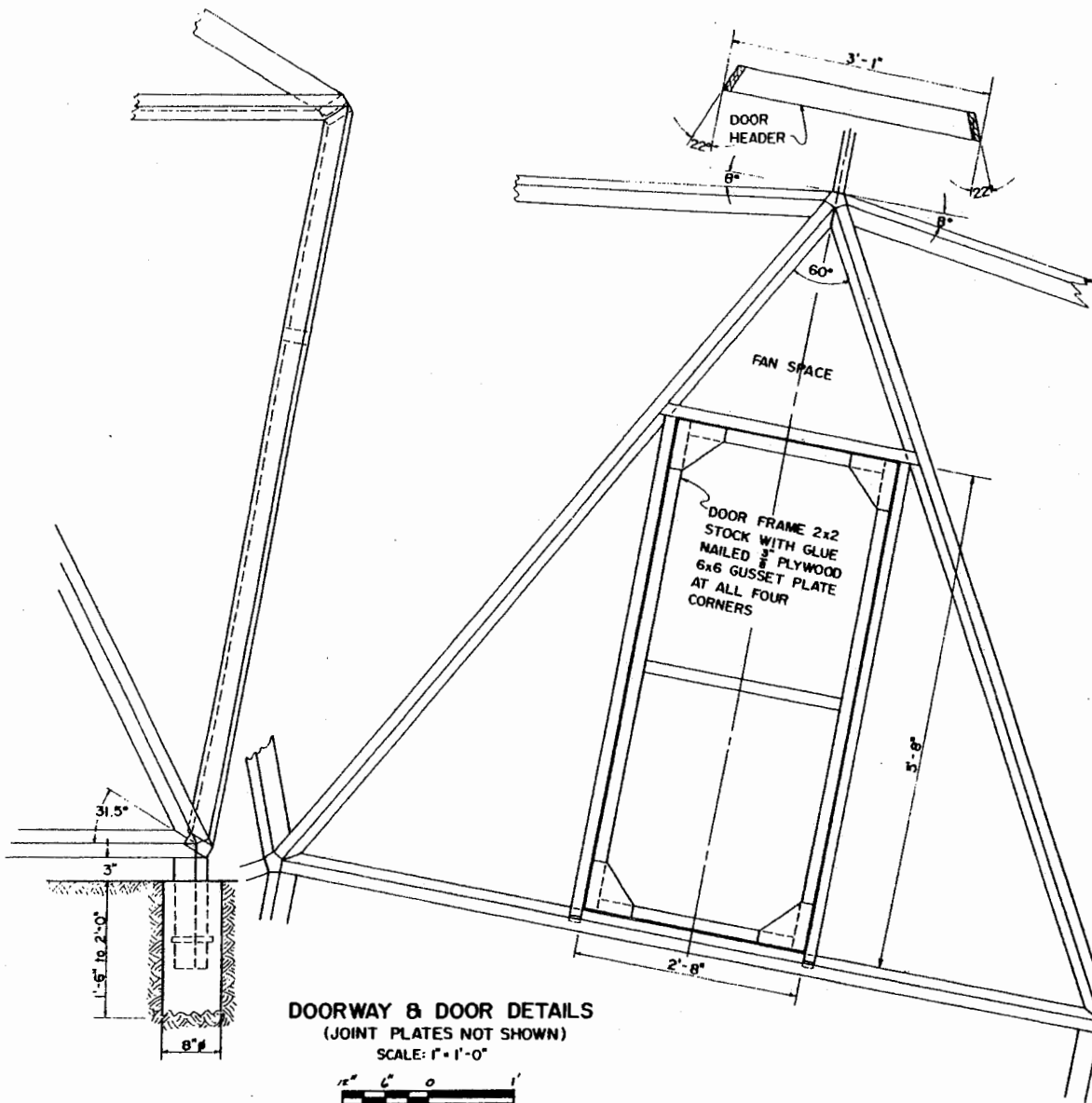

LAYOUT PLAN FOR FILM SECTIONS

SCALE: $\frac{1}{2}$ " = 10'-0"
 10' 5' 0' 10' 20'

DOORWAY & DOOR DETAILS

(JOINT PLATES NOT SHOWN)
 SCALE: 1" = 1'-0"

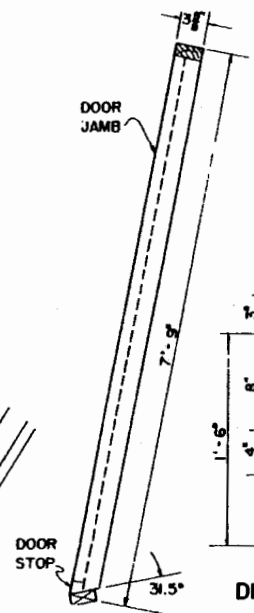
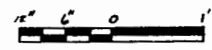

DETAIL OF ANCHOR STAKE

SCALE: $\frac{1}{2}$ " = 1'-0"



COVERING PROCEDURES

1. 6 MIL. POLY FILM SHOULD BE ORDERED IN 100'-0" ROLL, 10'-0" WIDE.
2. THIS SECTION WILL COVER 3 TRIANGULAR SURFACES; ONE CROWN AND TWO SIDE SURFACES.

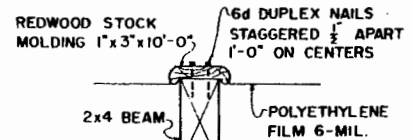

NAILING DETAIL

SCALE: 3" = 1'-0"

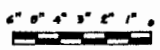

TRI-PENTA GREENHOUSE

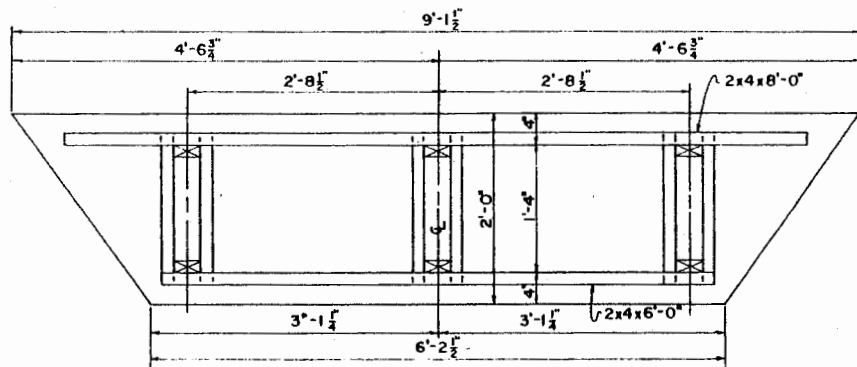

PLAN OF BENCH
4 REQUIRED
(SHOWING FRAME BELOW PANEL TOP)

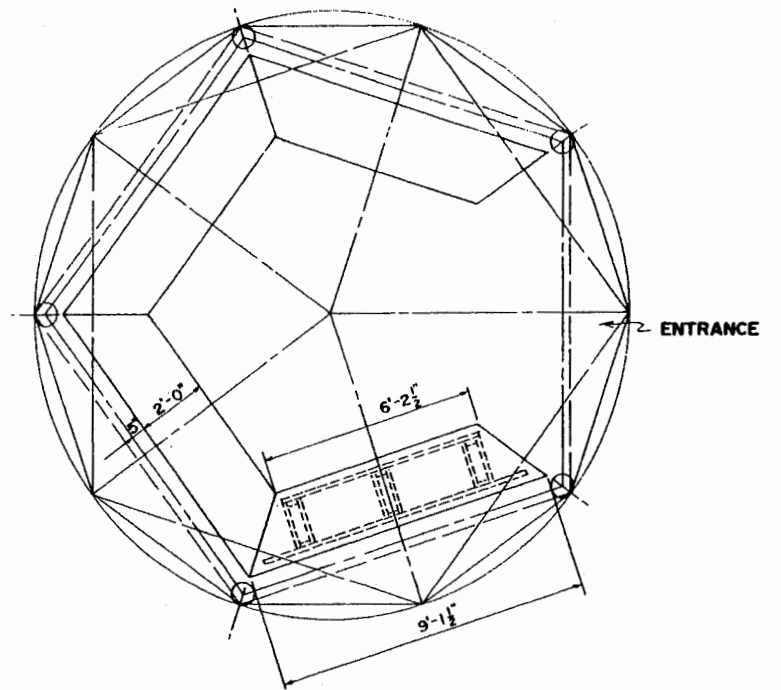

ARRANGEMENT OF BENCHES

SCALE: 3/8" = 1'-0"
0 1 2 3 4 5

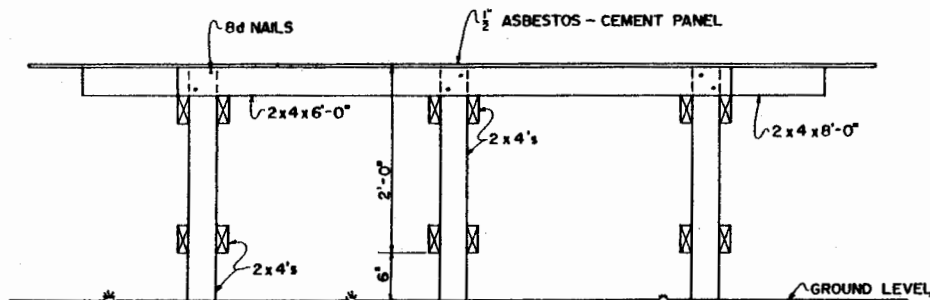

FRONT ELEVATION

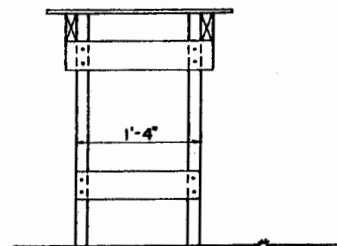

END ELEVATION



TRI-PENTA GREENHOUSE

USDA '71 6097 SHEET 3 OF 3

Disclaimer

This site makes available conceptual plans that can be helpful in developing building layouts and selecting equipment for various agricultural applications. These plans do not necessarily represent the most current technology or construction codes. They are not construction plans and do not replace the need for competent design assistance in developing safe, legal and well-functioning agricultural building system. The LSU Agriculture Center, the Mid-West Plan Service, the United States Department of Agriculture and none of the cooperating land-grant universities warranty these plans.